



GateMag® Electromagnetic Lock

In or Out... we make it Easy!

PLEASE DELIVER ALL INSTALLATION INSTRUCTIONS TO THE END-USER UPON COMPLETION OF THE INSTALLATION.

Pre-Installation Instructions

1. This product must be installed according to all applicable building and life safety codes.
2. Due to the variety of mounting configurations available with this product, a survey and assessment of the physical area in which the product will be installed must be performed.
3. The door frame must be inspected and deemed structurally sound prior to installation of the electromagnetic lock. The structural integrity of the mounting surfaces must be strong enough to meet or exceed the holding force of the product.
4. The product must be protected from potential damage due to intruders or tampering.
5. The product should be installed in a location that will not hinder or create a potential safety hazard to authorized personnel accessing the protected area.
6. Because electromagnetic locks are used in a variety of applications and different door frame configurations, an experienced installer with knowledge of this product must make a determination of the optimal mounting method for this specific application.
7. The components, hardware, installation instructions and mounting template included with this product are intended for use on outswinging doors and gates.
8. Do not use as a doorstop. This will void warranty.
9. Separate accessories not included with this product may be used in the following applications:
 - Inswinging doors and gates
 - Sliding gates and doors

Refer to the Template for further information.
10. Installation of this product should be done by an experienced installer with knowledge of this product.

NOTE: It is highly recommended that thread locking compound be applied to all screws during installation to reduce chance of screws loosening over extended time.

Instructions

1. Please read template mounting instructions and use template provided for installing the electromagnetic lock.

NOTE: During installation of the armature plate to the door it is essential that the armature plate remains movable. The armature plate must be allowed to pivot on the center-mounting bolt to allow proper alignment with the magnet surface. If the plate is not aligned with the magnet surface, the lock may lose holding force or not lock at all.

The head of the armature mounting bolt ships with a rubber washer affixed to it. This washer should project slightly beyond the surface of the armature plate. This is to allow the washer to expand when power is removed and break the air vacuum between the plate and the magnet surface. If this washer is removed or trimmed the lock will appear to have some holding force even when power is removed.

For added safety, thread locking compound has been provided for the armature plate bolt and the four electromagnetic lock mounting screws.

WARNING: Improper installation, maintenance, inspection or usage of the product or any related accessories or parts may cause the electromagnetic lock, armature plate and associated hardware to disengage and fall, causing serious bodily injury and property damage. Rutherford Controls Int'l Corp. will not be liable to the installer, purchaser, end user or anyone else for damage or injury to person or property due to improper installation, care, storage, handling, maintenance, inspection, abuse, misuse or act of God or nature involving this product or any related accessories or parts.

2. Connecting wire should be of sufficient gauge to prevent line loss.
3. The 8380 electromagnetic lock requires a filtered, regulated DC power source for optimal performance.

8380 Electromagnetic Lock Installation Instructions (Continued)

Wiring Instructions

WARNING – Misconnection of the wires will cause the MOV inside the electromagnetic lock to fail. This will NOT be covered under warranty.

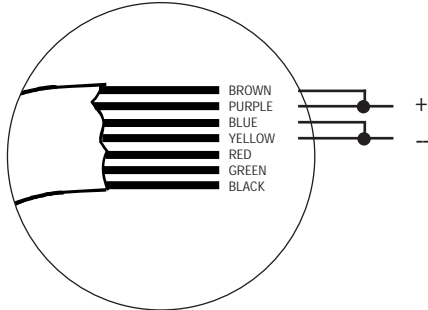

12 VDC INPUT

Twist brown and purple wires together and connect to positive side of power source. Twist blue and yellow wires together and connect to negative side of power source.

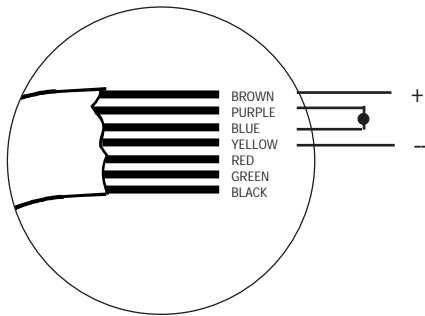

24 VDC INPUT

Twist purple and blue wires together; then connect brown wire to positive side of power source and yellow wire to negative side of power source.

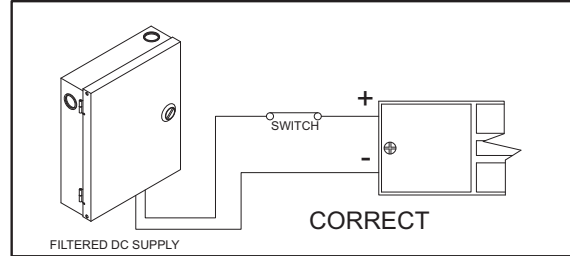
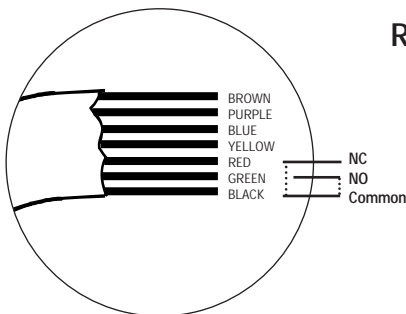

Fig. 2 – Power Connections

To Ensure Instant Release All switching devices must be wired in between the DC power source and the positive terminal of the lock in Fig 2.

Switching the negative power supply line will not allow the lock to release immediately. RCI electromagnetic locks contain MOV's for surge suppression and do not require any additional suppression to be added during installation. The installation of diodes across the lock input terminals will cause a delay in release.

Remote Lock Status



Magnet Locked – When the magnet is locked, the common contact (black) and the normally open contact (green or white) are closed. The normally closed contact (red) would be open.

Magnet Unlocked – When the magnet is unlocked, the common contact (black) and the normally closed contact (red) are closed.

Reed switch is operational when the magnetic lock is powered and the door is in the closed position.

Reed switch contacts are rated 24VDC @ 0.2amps maximum.

PLEASE DELIVER ALL INSTALLATION INSTRUCTIONS TO THE END-USER UPON COMPLETION OF THE INSTALLATION.

For product support, parts and ordering information contact:

Rutherford Controls Int'l Corp.

USA: 2697 International Parkway, Pkwy 5
Virginia Beach, VA 23452

Canada: 210 Shearson Crescent
Cambridge, ON N1T 1J6

Phone: 1-800-265-6630 / 1-519-621-7651

Fax: 1-800-482-9795 / 1-519-621-7939

E-mail: sales@rutherfordcontrols.com

Website: www.rutherfordcontrols.com

8380 Electromagnetic Lock Installation Instructions (Continued)

Troubleshooting		
Problem	Possible Cause	Solution
Door will not lock (no magnetic attraction)	Absence of DC voltage at magnet terminals	Check power supply and wiring.
Reduced holding force	Inadequate contact between armature and face of magnet.	Ensure mating surfaces are clean and in proper alignment. CAUTION: The armature plate must remain affixed securely to the door or serious bodily injury or property damage may occur. Bolt should be tight enough to hold the armature plate to the door while still allowing for alignment with the electromagnetic lock.
Delay in lock release	Circuit not broken (open) between power supply and magnetic lock.	Ensure that switching devices are interrupting the DC power and not the AC power supply voltage. Ensure rubber washer on armature plate mounting bolt has not been removed or damaged. Check that switching device interrupts the positive wire and not the negative wire. (See Figure 2)
	Secondary diode installed	Removed any diodes or other suppression devices that may be installed.
RLS status incorrect	Misalignment of armature plate	Check to see that alignment agrees with template. Reposition armature plate. Contact manufacturer.

Power Input Requirements

Voltage	Current
12VDC	0.48A
24VDC	0.24A

NOTE: Specifications are subject to change without notice.

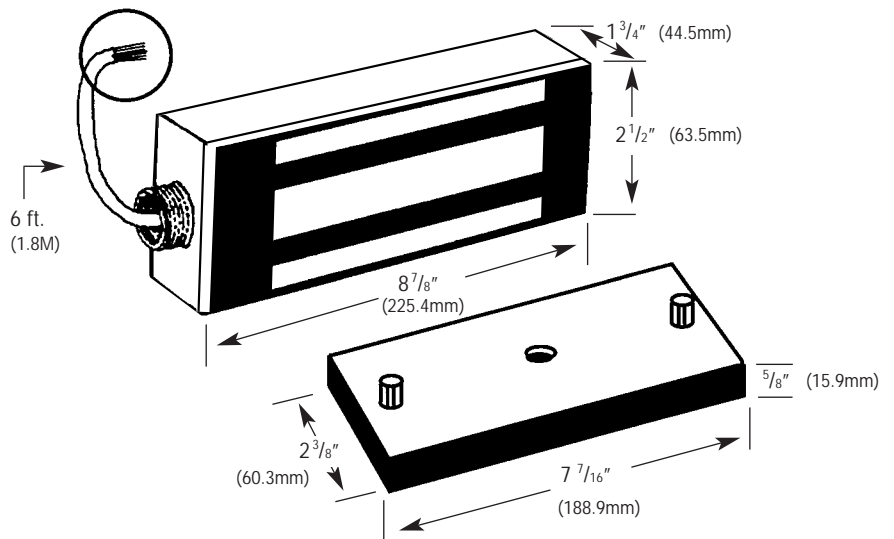

NOTE: All RCI electromagnetic locks must be powered with filtered and regulated DC power supplies such as the RCI 10 Series UL Listed power supply. RCI offers a full line of power supplies and switching devices that are suitable for use with the 8300 Series locks.

Inspection and Maintenance

This product and all related accessories or parts must be inspected and maintained on a quarterly basis. Contacting surfaces of the electromagnetic lock and armature plate must be kept free of contaminating materials. Surfaces must be cleaned periodically with a non-abrasive cleaner.

All mounting fasteners must be inspected on a quarterly basis. When properly installed, the ends of the armature plate allow a slight movement but the plate will feel secure when grasped at the bolt. There should be no movement to the mounting bracket or housing of the electromagnetic lock.

For added safety, thread locking compound has been provided for the armature plate bolt and the four captive electromagnetic lock mounting screws.

WARNING: Improper installation, maintenance, inspection or usage of the product or any related accessories or parts may cause the electromagnetic lock, armature plate and associated hardware to disengage and fall, causing serious bodily injury and property damage.

8380 Electromagnetic Lock Installation Instructions (Continued)

WIRE GAUGE SELECTIONS

Total One Way Length of Wire Run (ft.)	Load Current @24V							
	1/4A	1/2A	3/4A	1A	1-1/4A	1-1/2A	2A	3A
100	24	20	18	18	16	16	14	12
150	22	18	16	16	14	14	12	10
200	20	18	16	14	14	12	12	10
250	18	16	14	14	12	12	12	10
300	18	16	14	12	12	12	10	--
400	18	14	12	12	10	10	--	--
500	16	14	12	10	10	--	--	--
750	14	12	10	10	--	--	--	--
1000	14	10	10	--	--	--	--	--
1500	12	10	--	--	--	--	--	--

Total One Way Length of Wire Run (ft.)	Load Current @12V							
	1/4A	1/2A	3/4A	1A	1-1/4A	1-1/2A	2A	3A
100	20	18	16	14	14	12	12	10
150	18	16	14	12	12	12	10	--
200	16	14	12	12	10	10	--	--
250	16	14	12	10	10	10	--	--
300	16	12	12	10	10	--	--	--
400	14	12	10	--	--	--	--	--
500	14	10	10	--	--	--	--	--
750	12	10	--	--	--	--	--	--
1000	10	--	--	--	--	--	--	--
1500	10	--	--	--	--	--	--	--

Wire Gauge Chart courtesy of Electronic Locking Devices by John L. Schum