

Early Warning Electromagnetic Lock



In or Out... we make it Easy!

PLEASE DELIVER ALL INSTALLATION INSTRUCTIONS TO THE END-USER UPON COMPLETION OF THE INSTALLATION.

Pre-Installation Instructions

1. This product must be installed according to all applicable building and life safety codes. All installations must be approved by the Authority Having Jurisdiction (AHJ).
 2. Due to the variety of mounting configurations available with this product, a survey and assessment of the physical area in which the product will be installed must be performed.
 3. The door frame must be inspected and deemed structurally sound prior to installation of the electromagnetic lock. The structural integrity of the mounting surfaces must be strong enough to meet or exceed the holding force of the product.
 4. The product must be protected from potential damage due to intruders or tampering.
 5. The product should be installed in a location that will not hinder or create a potential safety hazard to authorized personnel accessing the protected area.
 6. Because electromagnetic locks are used in a variety of applications and different door frame configurations, an experienced installer with knowledge of this product must make a determination of the optimal mounting method for this specific application.
 7. The components, hardware, installation instructions and mounting template included with this product are intended for use on outswinging doors.
 8. Do not install this product on the exterior of buildings.
 9. Do not use as a doorstop. This will void warranty.
 10. Separate accessories not included with this product must be used in the following applications:
 - Narrow head jamb situations or center-hung doors
 - Wherever there is insufficient space on the door frame header to mount the lock
 - Hollow metal or wood frames where the door stop is not thick enough to allow the product to be installed
 - Wherever an obstruction in the door prevents installation of the armature plate at a proper height
 - Doors that do not permit the armature plate to be mounted low enough to meet the magnet surface
- Refer to the Product Accessories Guide section of the Installation Instructions for further information.
11. Installation of this product should be done by an experienced installer with knowledge of this product.
 12. A mechanical latching device is recommended in conjunction with the Early Warning 8310 to maintain security during a power failure.
- NOTE:** It is highly recommended that thread locking compound be applied to all screws during installation to reduce chance of screws loosening over extended time.

Installation Instructions

1. Mount the electromagnetic lock to the door frame as outlined on the installation template included with the product.

Armature Plate Mounting Notes:

- 1) It is essential that this plate pivot slightly on the mounting bolt to allow proper alignment with the magnet surface. If not aligned, the lock may lose holding force or not lock at all.
- 2) The rubber washer on the head of the mounting bolt should project slightly beyond the surface of the armature plate. It will expand when power is removed and break the air vacuum between the plate and magnet. If removed or trimmed, the lock will appear to have some holding force even when power is removed.

For added safety, thread locking compound has been provided for the armature plate bolt and the four captive electromagnetic lock mounting screws.

WARNING: Improper installation, maintenance, inspection or usage of the product or any related accessories or parts may cause the electromagnetic lock, armature plate and associated hardware to disengage and fall, causing serious bodily injury and property damage. Rutherford Controls Int'l Corp. will not be liable to the installer, purchaser, end user or anyone else for damage or injury to person or property due to improper installation, care, storage, handling, maintenance, inspection, abuse, misuse or act of God or nature involving this product or any related accessories or parts.

2. Route the power supply connecting wire through the door frame and into the wire access hole in the top of the magnet housing. Connecting wire should be of sufficient gauge for the lock being installed and the distance being run. See table for current draw specifications and wiring gauge chart.
3. See system overview and switching options.

EW8310 Early Warning Electromagnetic Lock Installation Instructions (Continued)

Early Warning System – Overview

The Early Warning electromagnetic lock is a fail safe device.

In the normal condition with power, the door is locked, the light panel blinks green, the Local Alarm SPDT relay is de-energized and the Remote Alarm DPDT relay is energized.

The alarm sequence starts with a direct pull on the door. A Nuisance Delay is set for 4 seconds. During this time the light panel will blink red and the Local Alarm relay will be energized to warn that someone is attempting to force open the secured lock. If the pressure on the door is withdrawn during the Nuisance Delay Period, the system returns to normal conditions. This would be considered accidental triggering.

If pressure is maintained past the Nuisance Delay Period, the Remote Alarm Period of 30 second will begin. In addition to the light panel blinking red and the energized Local Alarm, the Remote Alarm relay will now be de-energized.

At the end of the 30 second Remote Alarm Period, if the pressure has been withdrawn, the Local and Remote Alarm relays will return to the normal condition. The light panel however will continue to flash red and green until reset. If pressure is reapplied to the door, the system goes directly to the 30 second Remote Alarm Period activation of both relays.

If the door is forced open, the light panel will immediately blink red, the Local Alarm relay will be energized and the Remote Alarm relay will be de-energized. Even if the door is subsequently closed, all indicators will remain activated until the system power is turned off.

Easy connections are provided for an external sounder or buzzer. At an accidental triggering, an audible pulse is generated with a steady sound during the 30 second Remote Alarm period. A forced open status will provide a pulsing sound until reset.

Request to exit connections and access control wiring are detailed on pages 4 and 5.

Lock Assembly

The Early Warning electromagnetic lock comes with screws that inhibit the insertion of an Allen wrench into the mounting bolt openings on the underside of the lock. These screws will need to be removed prior to installation to allow the mounting plate to be removed from the top of the lock.

Fig 1 illustrates the location of these screws.

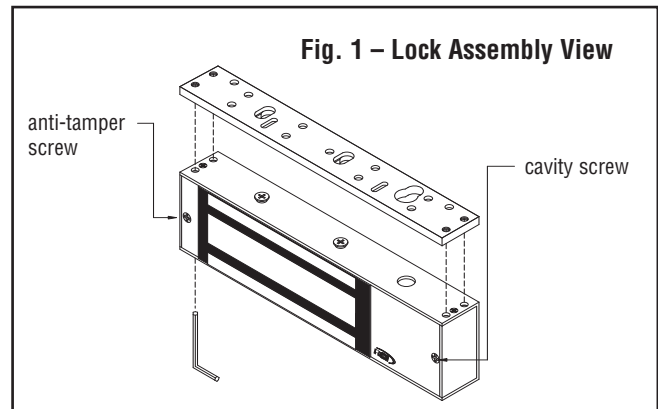

Early Warning Lock – Status Indicators

System Status	Light Panel	Optional External Buzzer	Local Alarm Relay	Remote Alarm Relay
Door Open	Red on	OFF	OFF	OFF
Locked	Green blinks every 5 seconds	OFF	OFF	ON
4 second Nuisance Delay Period	Red blinking (fast)	Pulsing Sound	ON	ON
30 second Remote Alarm Period	Red blinking (slowly)	Steady Sound	ON	OFF
Alarm Requires Reset	Red/Green blinking alternately	OFF	OFF	ON
Forced Open*	Red blinking (fast)	Pulsing Sound	ON	OFF
Exit Switch to Open	Red On	OFF	OFF	OFF

* A drop in voltage will also generate the same status indicators as forced open. Shutting down the system power is required for reset.

If power is removed entirely, the fail safe Early Warning Lock releases and all indicators shut down. The door is secured by the mechanical latching only until power is restored and the Early Warning Lock resets.

EW8310 Early Warning Electromagnetic Lock Installation Instructions (Continued)

Specifications

LISTING  us Auxiliary Lock.

This product has been successfully tested and evaluated by UL for use in both the United States and Canada.

Our GWXT fire listing qualifies the EW8310 series as an “Auxiliary Lock” for use with UL Classified fire doors maximum 4' in width and 8' in height, rated up to and including 1-1/2 hr with the “Positive Pressure Fire Test of Door Assemblies”, ANSI/UL 10C.

The product is also classified in accordance with Uniform Building Code Standard 7-2, Fire Test of Door Assemblies, (1997)

Patent Pending

MECHANICAL:

EW8310 Lock Dimensions

Including 1/4" (6.4mm) mounting bracket:
2-1/8"D x 2-7/8"H x 10-13/16"L (54mm x 73mm x 275mm)

EW8310 Armature Plate Dimensions:

5/8"D x 2-3/8"H x 7-7/16"L (16mm x 60mm x 189mm)

ELECTRICAL:

Auto Sensing Voltage: 12VDC to 30VDC

Power Consumption: 12VDC - Max 0.58A
24VDC - Max 0.29A

Local Alarm Output: SPDT 1.0A 120VAC, 2A 30VDC

Remote Alarm Output: DPDT: 1.0A 120VAC, 2A 30VDC

ENVIRONMENTAL:

Not for use in outdoor environments.

Circuit board operating temperature: -14 to 140°F (-10 to 60°C)

NOTE: The EW8310 electromagnetic lock must be powered with a filtered and regulated DC power supply rated 12 to 30V. RCI recommends our 10 Series Power Supplies and full line of switching devices.

The magnet warranty is 10 years.

Specifications subject to change without notice.

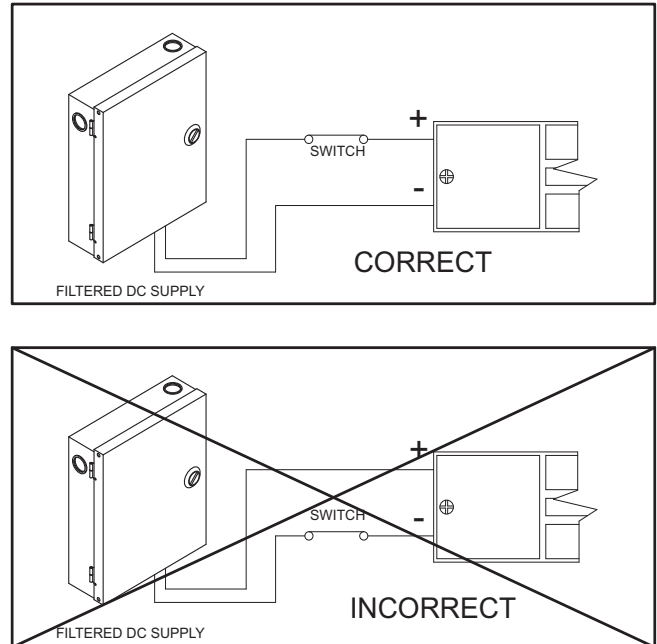

Fig. 2 – Power Connections

To Ensure Instant Release All switching devices must be wired in between the DC power source and the positive terminal of the lock as illustrated in Fig 2.

Switching the negative power supply line will not allow the lock to release immediately. RCI electromagnetic locks contain MOV's for surge suppression and do not require any additional suppression to be added during installation. The installation of diodes across the lock input terminals will cause a delay in release.

Low Voltage Detection

Each circuit board includes a low voltage detection circuit that is enabled when shipped from the factory. This feature will cause the alarm relay and status LED to activate should the lock input voltage drop below 9.5VDC. That signals a monitored system or guard station that the holding force of the lock may have been compromised.

EW8310 Early Warning Electromagnetic Lock Installation Instructions (Continued)

Circuit Board Connections

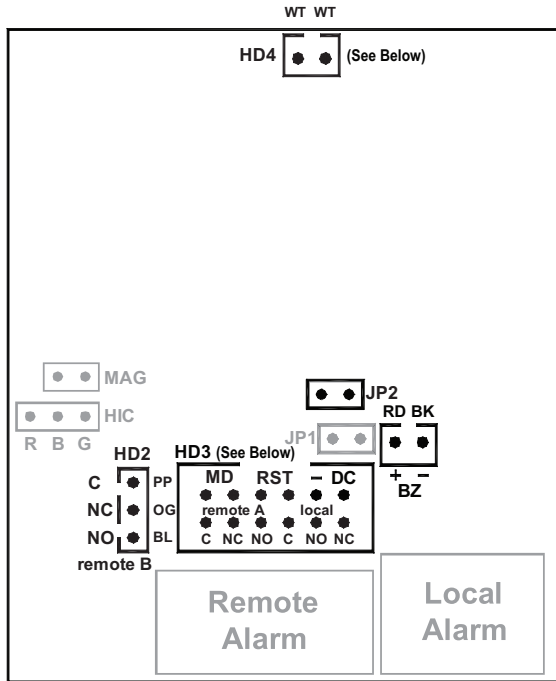

- HD4:** N/O momentary request to exit switch (5 second built in release)
- BZ:** 9VDC output to Buzzer max 100mA
- HD2:** Same as Remote A below
- JP2:** Jumper off to enable low voltage detection (factory default)
Jumper on to disable low voltage detection

HD3 Main Harness

- RST:** Connect the 2 brown leads to reset switch
- DC:** DC power wires; black is negative (-) and Red is positive (+)
- Remote A** Purple is common (C)
Orange is normally closed (NC)
Blue is normally open (NO)
- Local:** Grey is common (C)
Green is normally open (NO)
Pink is normally closed (NC)

Wiring Diagram

Diagram reflects status with power on and door opened.

A mechanical latching device is recommended in conjunction with the Early Warning 8310 to maintain security during a power failure.

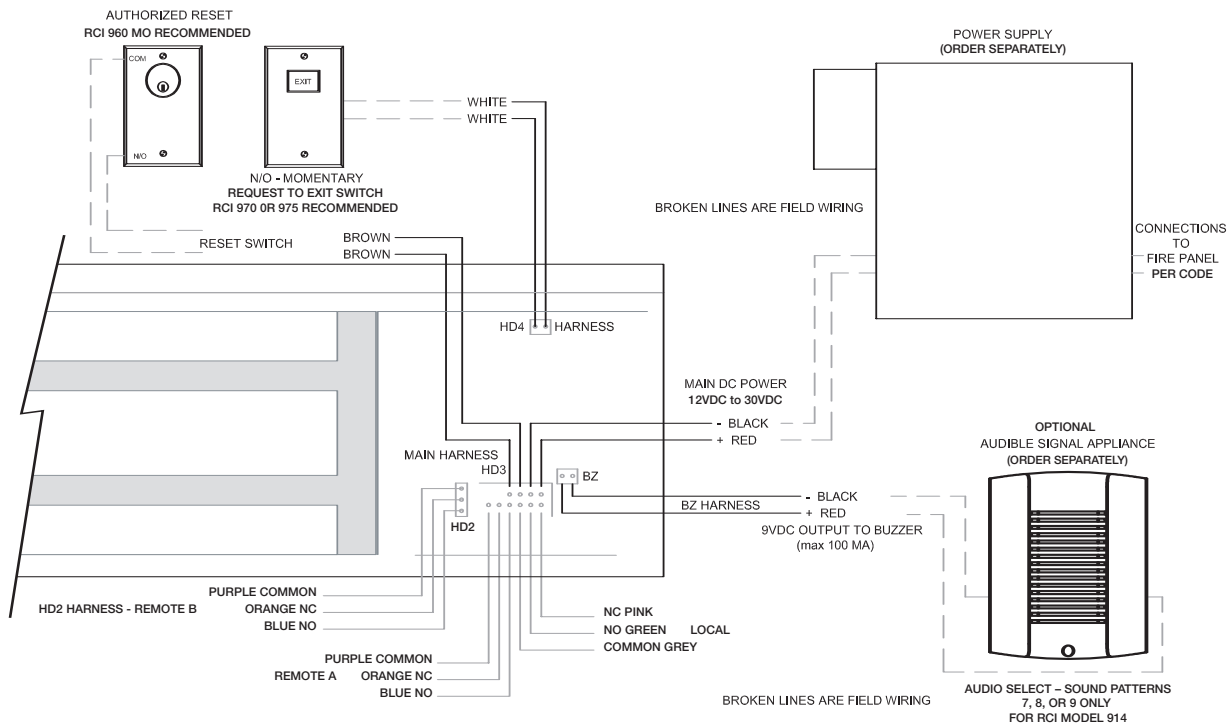

EW8310 Early Warning Electromagnetic Lock Installation Instructions (Continued)

Alternate Access Control Wiring Diagram

Diagram reflects status with power on and door opened.
A mechanical latching device is recommended in conjunction with the Early Warning 8310 to maintain security during a power failure.

- NOTE:**
- 1.) Unlock time is determined by the access control device.
 - 2.) The access control device must be set for fail safe operation.

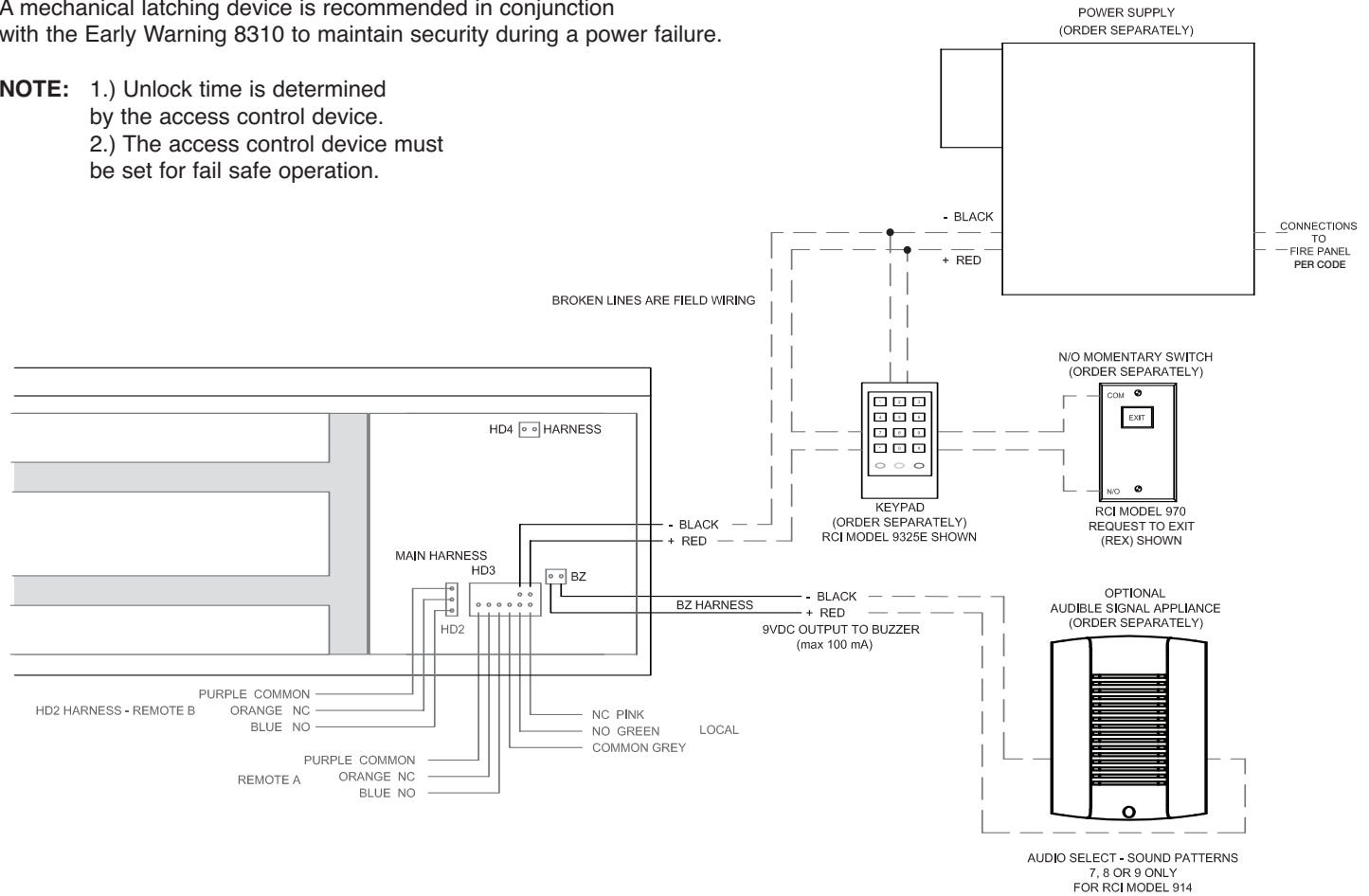

Inspection and Maintenance

This product and all related accessories or parts must be inspected and maintained on a quarterly basis. Contacting surfaces of the electromagnetic lock and armature plate must be kept free of contaminating materials. Surfaces must be cleaned periodically with a non-abrasive cleaner.

All mounting fasteners must be inspected on a quarterly basis. When properly installed, the ends of the armature plate allow a slight movement but the plate will feel secure when grasped at the bolt. There should be no movement to the mounting bracket or housing of the electromagnetic lock.

For added safety, thread locking compound has been provided for the armature plate bolt and the four captive electromagnetic lock mounting screws.

WARNING: Improper installation, maintenance, inspection or usage of the product or any related accessories or parts may cause the electromagnetic lock, armature plate and associated hardware to disengage and fall, causing serious bodily injury and property damage.

PLEASE DELIVER ALL INSTALLATION INSTRUCTIONS TO THE
END-USER UPON COMPLETION OF THE INSTALLATION.

For product support, parts and ordering information contact:

Rutherford Controls International Corp.
USA: 2697 International Parkway, Pkwy 5
Virginia Beach, VA 23452

Canada: 210 Shearson Crescent
Cambridge, ON N1T 1J6

Phone: 1-800-265-6630 Fax: 1-519-621-7939
E-mail: sales@rutherfordcontrols.com
Website: www.rutherfordcontrols.com

EW8310 Early Warning Electromagnetic Lock Installation Instructions (Continued)

EW8310 Early Warning Series Troubleshooting Guide

PROBLEM	SOLUTION
Cannot remove the lock mounting bracket from top of magnet for installation.	Remove anti-tamper screw and cavity screw. Insert supplied Allen wrench into mounting bolt holes in the bottom of the lock housing and turn. (See Fig.1)
Lock is installed but has no holding force at all.	Check power supply. DC power should be within 12-30VDC. Check connections at power supply, connected releasing devices, lock terminals and lock circuit board to magnet core.
Lock has enough holding force to lightly hold a screwdriver or set of pliers but door will not lock.	Check to see that armature plate is correctly aligned with the electromagnetic lock. If there is improper alignment, make a 1/4" turn of the armature plate mounting bolt and check for alignment. CAUTION: The armature plate must remain affixed securely to the door or serious bodily injury or property damage may occur. Bolt should be tight enough to hold the armature plate to the door while still allowing for alignment with the electromagnetic lock.
Lock is operating and locking but the armature plate is "humming" against the surface of the lock.	This generally indicates that the lock is either operating on AC voltage or there is some AC voltage present in the DC supply. A properly filtered and regulated DC power supply is required to achieve optimal operation from the lock.
Lock is not releasing immediately upon removal of power	Ensure that switching devices are interrupting the DC power and not the AC power supply voltage. Ensure rubber washer on armature plate mounting bolt has not been removed or damaged. Check that switching device interrupts the positive wire and not the negative wire (See Fig. 2). Remove any Diodes or other suppression devices that may be installed.

EW8310 Early Warning Electromagnetic Lock Installation Instructions (Continued)

Product Mounting Accessories Guide (Separate installation instructions provided with accessories.)

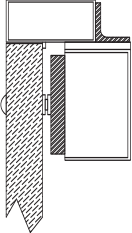
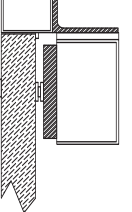
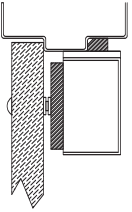
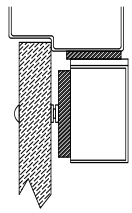
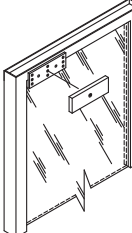
PART	USAGE	EXAMPLE
<p>Angle Bracket</p>	<p>Used in a narrow head jamb situation or for center-hung doors. Any place where there is insufficient frame depth to mount the lock. The Early Warning uses the same angle bracket as the RCI standard 8310.</p> <p>Available in several different sizes and finishes.</p>	
<p>“L” Bracket</p>	<p>Required wherever there is insufficient space on the frame header to mount the lock. The lock mounts to the underside of the “L” bracket and the “L” bracket then gets mounted to the doorframe.</p> <p>Available in several different sizes and finishes.</p>	
<p>Filler Bars</p>	<p>Used to provide extra mounting space in a hollow metal or wood frame where the door stop of the frame is not thick enough to allow a lock to be installed. The Early Warning uses the same filler bars as the RCI standard 8310.</p> <p>Available in several different widths.</p>	
<p>Spacer Bars</p>	<p>For use when an obstruction in the door prevents the installation of the armature plate at a proper height. If the armature plate needs to be lowered then a spacer bar can be used to lower the lock from the frame.</p> <p>Available in several different thickness.</p>	
<p>Armature Holder</p>	<p>For use with doors that do not permit the armature plate to be mounted low enough to meet the magnet surface. Eg: Some aluminum framed commercial glass doors. The armature holder can be mounted to whatever frame is available and the armature plate in turn mounted to the holder.</p> <p>Available in both flat (shown) and pocket styles.</p>	

Also Available Separately:

CTS10 - Cover Tamper Switch for wiring cavity
 CSS10 - Cavity Security Screw Kit
 (tamperproof fasteners & driver for wiring cavity cover)

EW8310 Early Warning Electromagnetic Lock Installation Instructions (Continued)

WIRE GAUGE SELECTIONS

Total One Way Length of Wire Run (ft.)	Load Current @24V							
	1/4A	1/2A	3/4A	1A	1-1/4A	1-1/2A	2A	3A
100	24	20	18	18	16	16	14	12
150	22	18	16	16	14	14	12	10
200	20	18	16	14	14	12	12	10
250	18	16	14	14	12	12	12	10
300	18	16	14	12	12	12	10	--
400	18	14	12	12	10	10	--	--
500	16	14	12	10	10	--	--	--
750	14	12	10	10	--	--	--	--
1000	14	10	10	--	--	--	--	--
1500	12	10	--	--	--	--	--	--

Total One Way Length of Wire Run (ft.)	Load Current @12V							
	1/4A	1/2A	3/4A	1A	1-1/4A	1-1/2A	2A	3A
100	20	18	16	14	14	12	12	10
150	18	16	14	12	12	12	10	--
200	16	14	12	12	10	10	--	--
250	16	14	12	10	10	10	--	--
300	16	12	12	10	10	--	--	--
400	14	12	10	--	--	--	--	--
500	14	10	10	--	--	--	--	--
750	12	10	--	--	--	--	--	--
1000	10	--	--	--	--	--	--	--
1500	10	--	--	--	--	--	--	--

Wire Gauge Chart courtesy of Electronic Locking Devices by John L. Schum