

**O SERIES COMMERCIAL ELECTRIC STRIKE
CENTERLINE LATCH ENTRY FOR RIM EXIT DEVICE***In or Out... we make it Easy!***Installation Instructions**

1. For new installations, surface mount 0161 strike first, then install exit device accordingly maintaining a minimum of $\frac{3}{8}$ " clearance.
2. Determine the horizontal center line 'G' of the Pullman Latch of the exit device, and transfer to frame stop. (see fig. 1)
3. Determine the vertical center line of the Electric Strike 'X' by adding $\frac{3}{4}$ " to dimension "R" (See Fig.1) and measure from the push side of the door to frame stop for 'X'.
4. Prepare door jamb as per template drawing for full surface mounting. (see preparation "V")
5. Ensure that strike insert is placed in the center most position on the faceplate prior to installation. This allows for maximum adjustability when installation is complete (see Fig. 2).
6. Connect wires from power source to terminal screws on strike (polarity is not observed).
7. Using slotted holes in chassis, install exit device electric strike with 2 SHCS $\frac{1}{4}$ - 20 x 1", socket head cap screws provided.
8. Adjust chassis and electric insert (if necessary), horizontally, until Pullman Latch engages when door is closed. Finally tighten screws.
Important: Be sure exit device dead locks when door is closed before proceeding to step 9.
9. Mark, drill and tap for the locking screws provided, and install to secure final location with 2 SHCS $\frac{1}{4}$ - 20 x 1", screws provided.

Note:

If further adjustment is needed later, to correct door or weatherstrip misalignments, horizontally move insert on its furrows by loosening screws under the face plate, and re-tighten when in the corrected position (Fig. 2.).

Important:

The 0161 Electric Strike is never to be used as a door stop. Please install stops on frame in appropriate locations. Ensure the exit device functions as intended for life safety concerns by verifying electric strike and exit device compatibility. Maximum latch projection is essential to obtain full holding force.

0161 Series Installation Instructions (Continued)

Template For 0 Series Strikes

MODEL # 0161

MEASUREMENT	FRACTIONAL INCHES	DECIMAL INCHES	METRIC mm
C	1 5/8	1.625	41.3
G	Horizontal center line of Pullman Latch		
K	4 1/8	4.125	105
M	1/4 - 20 Tap		
O	5/16"	.312	8
P	2 1/2	2.5	63
Q	1 3/8	1.375	35
V	Preparation for mortising electric insert for model 0161		
X	Vertical center line of 0161		

Insert Semi-mortise Mounting Preparation "V"

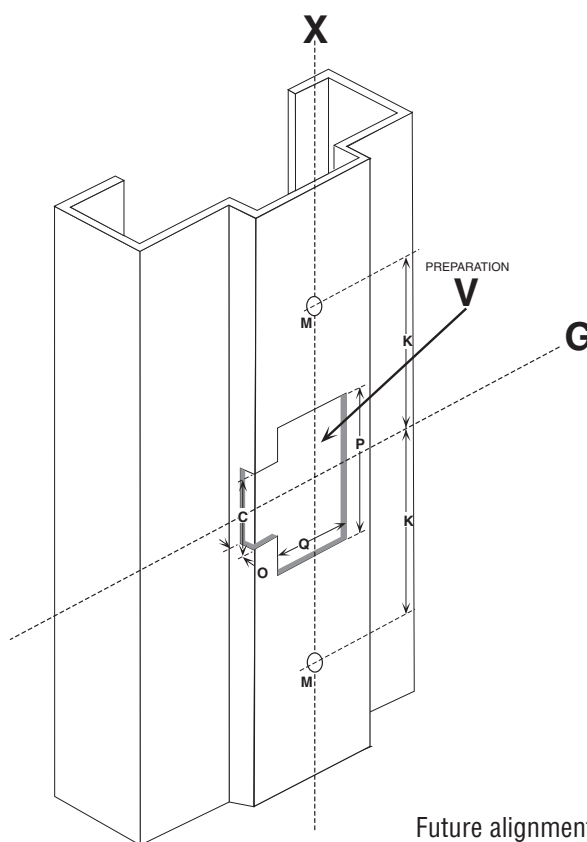

IMPORTANT

If Exit Device Strike (supplied with device) is of 1/2" or 5/8" projection, please use "Insert Semi-mortise Mounting" or Preparation "V".

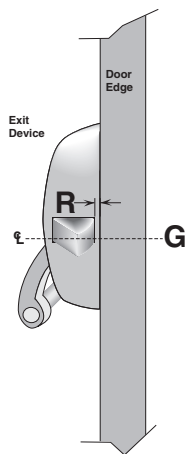
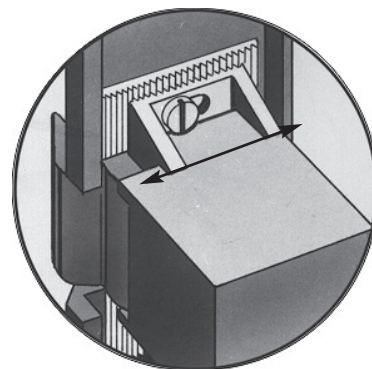

Fig.1

Future alignment problems can be corrected by loosening the two insert screws and moving the



insert horizontally across the furrows. Original preparation is not disturbed. (Fig.2).

Note: DO NOT SCALE SPECIFICATIONS SUBJECT TO CHANGE WITHOUT NOTICE.