



In or Out... we make it Easy!

Standard Parts:	Accessories:
Insert	Latch Monitor Switch - F2LM
Deadbolt Bracket	
Deadbolt Plug	
Guardbolt Bracket (Auxiliary Bolt Bracket)	
Keeper Shims: 1/16" (1.5mm) & 1/8" (3.0mm)	
A Center-lined latch faceplate and an Offset latch faceplate are provided. Both are: 4-7/8" x 1-1/4" (123.8mm x 31.8mm)	
Trim Plate	
12VDC or 12 to 24VAC Cable Connector	
24VDC Cable Connector	
Tamper Proof Strike Mounting Screws (2pcs)	

The fail secure locking mechanism shall only be installed where allowed by the local authority having jurisdiction and shall not impair the operation of the panic hardware or intended operation of the emergency exit.

Wiring Instructions

Use the appropriate wire harness supplied.

12V for 12VDC & 12-24VAC

24V for 24VDC only

Attach the red wire to (+) positive of the power supply. Attach the black wire to the (-) negative of the power supply.

If using AC power, polarity is not observed.

NOTE: If a suppression diode is required for access control, observe proper polarity.

Latch Monitor Wires

Black = Common (C)

Blue = Normally Close (NC)

Orange = Normally Open (NO)

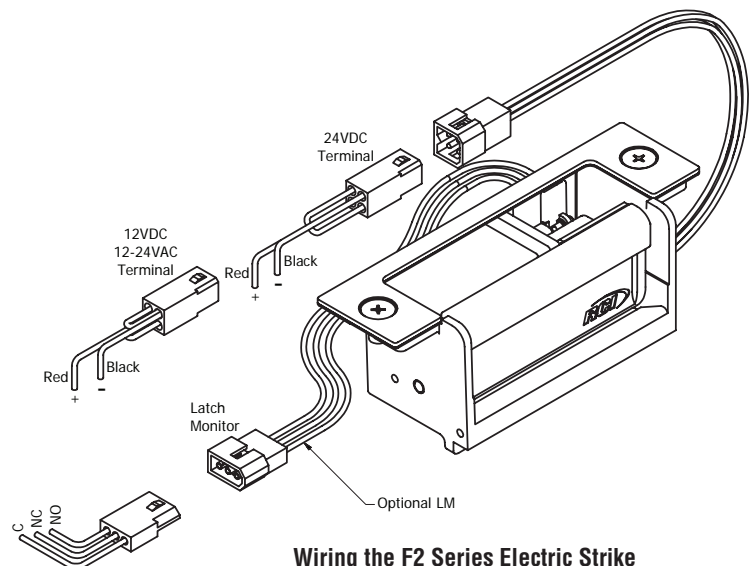

Wiring the F2 Series Electric Strike

Model F2164 must be connected to a compatible UL Listed Burglary or Access Control Power Supply.

F2164 Installation Instructions (Continued)

1. Mount the strike onto the frame without the faceplate. Tighten the mounting screws just enough to hold the strike in place; you may need to slide it up-down for adjustment.



Adjust Deadbolt Bracket:

First, extend the deadbolt and move the door so that deadbolt touches the keeper.

Mark deadbolt limit lines on keeper.

Then, open the door and retract the deadbolt. Adjust the deadbolt bracket position so that it captures deadbolt limit lines marked on keeper. Move the strike up-down if needed.



Adjust Guardbolt Bracket:

First, move the door towards the strike so that the guardbolt touches the keeper.

Mark guardbolt limit lines on keeper.

Then, open the door. Adjust the guardbolt bracket so that it captures guardbolt limit lines marked on keeper.



F2164 Installation Instructions (Continued)

Adjust Latch Monitor Module Accessory:

First, move the door towards the strike so that the latch touches the keeper.

Mark latch limit lines on keeper.

Then, open the door. Mount the Latch Monitor Module on the strike housing so that it is between the latch limit lines marked on keeper.



2. Mark strike position on the frame.



3. Peel the adhesive backing from tape on the back side of the appropriate faceplate. Remove the strike mounting screws. Hold the strike in position as marked on frame. Carefully position the faceplate onto the strike and secure to the frame.



F2164 Installation Instructions (Continued)

Horizontal Adjustment: If there is play in the door when closed; the keeper shims may be used to minimize play.



Trim Plate: This can be used in case the frame cutout is bigger than required.

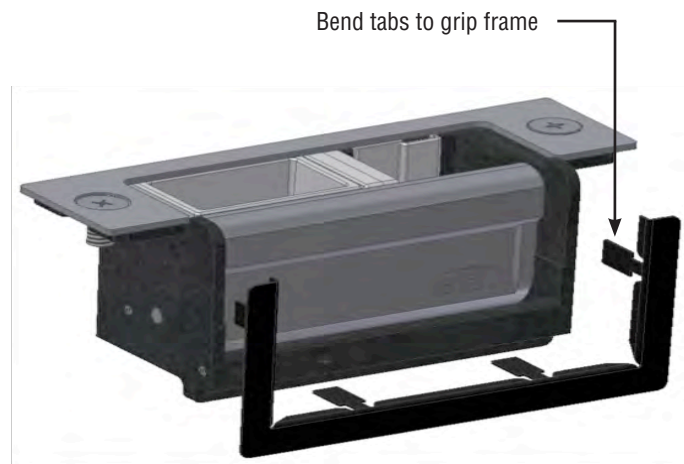

Deadbolt Plug: If the lock set doesn't have a deadbolt, then replace deadbolt bracket with deadbolt plug.

